

MECHANICS OF FLUIDS

Fluids are both liquids and gases. The common property of fluids is that the particles can be separated easily (liquids do not have their own “shape” etc.). Real fluids have something like internal friction = viscosity, so e.g. the stream in the middle of the tube in which a fluid moves is faster than near the walls. An ideal fluid would have the same speed in the whole cross-section.

Ideal liquids are incompressible, which is valid in fact for real liquids as well.

Ideal gases can be compressed to zero volume.

A: FLUIDS AT REST

1. Pressure in a liquid

- revision:

$$\text{pressure } p = \frac{F}{A}$$

$$[p] = \frac{\text{N}}{\text{m}^2} = \text{Pa (pascal)}$$

pressure is a scalar!!!

$$\text{density } \rho = \frac{m}{V}$$

$$[\rho] = \frac{\text{kg}}{\text{m}^3} = \text{kg} \cdot \text{m}^{-3}$$

a) pressure caused by outer force acting on a closed liquid

Pascal's principle

$$p = \frac{F}{A}$$

this pressure is the same within the whole liquid

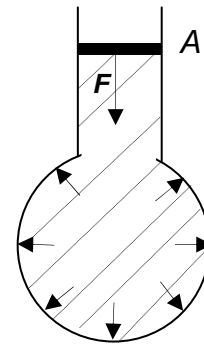

According to Pascal's principle, pressure applied to any part of an enclosed fluid is transmitted to all other parts.

Use: hydraulic principle (brakes, jacks for lifting cars ...)

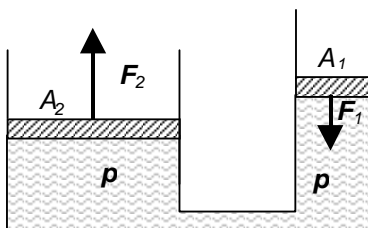

$$p = \frac{F_1}{A_1} = \frac{F_2}{A_2}$$

b) pressure due to a liquid column (in the gravitational field)

As the molecules of a liquid are attracted towards the Earth, this pressure will rise with increasing depth (measured from the open surface of the liquid!).

$$p_h = \frac{F}{A} = \frac{mg}{A} = \frac{V\rho g}{A} = \frac{Ah\rho g}{A} = h\rho g$$

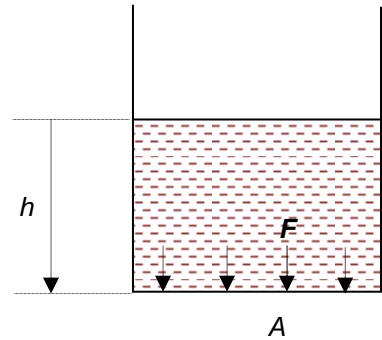

2. Uses of liquid columns

a) manometers (measurement of pressure)

i) Toricelli's experiment – used to state atmospheric pressure p_a

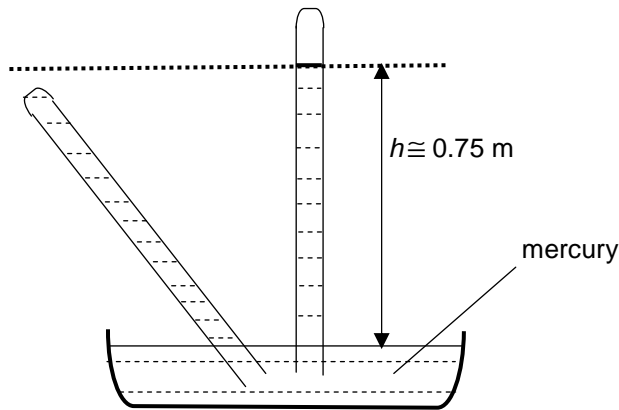

$$p_h = h\rho g = 0.75\text{ m} \times 13600\text{ kg} \cdot \text{m}^{-3} \times 9.81\text{ m} \cdot \text{s}^{-2} = 10^5\text{ Pa} = p_a$$

ii) in labs

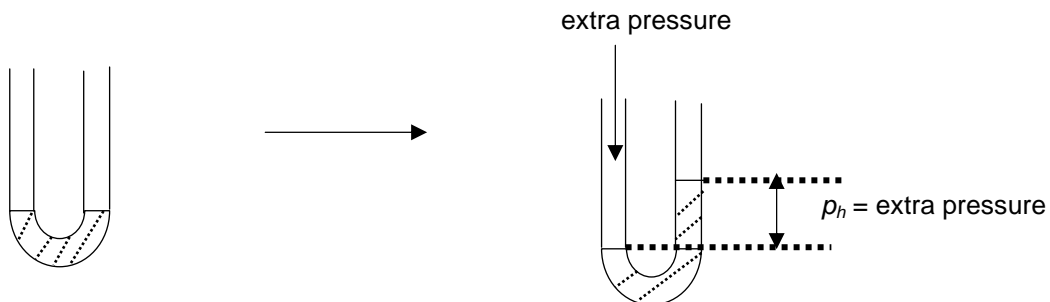

b) measurement of density

i) immiscible liquids

ρ_1 ... known, ρ_2 ... unknown

$$p_{h1} = p_{h2}$$

$$h_1 \rho_1 g = h_2 \rho_2 g$$

$$\rho_2 = \frac{h_1 \rho_1}{h_2}$$

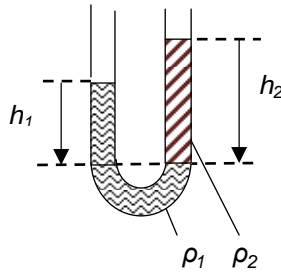

ii) miscible liquids – should be separated by mercury – derive the eqn.

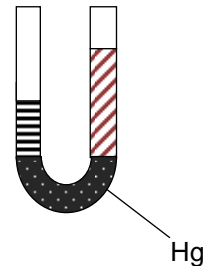

Questions:

1. Pistons of a hydraulic press have cross-section areas 5 cm^2 and 400 cm^2 respectively. If we act by the force 100 N on the narrow piston, stipulate the pressure exerted in the liquid and also the force acting on the wider piston.
2. What hydrostatic force acts on the bottom of the water reservoir at a depth 5 m if the area of the bottom is 50 m^2 ? What is the pressure at this depth?
3. A scuba diver descends to the bed of a lake to a depth 11 m . What is the pressure there?
4. In one limb of the U-tube is water, in another is oil. The height of water above the common boundary is 7.2 cm , the height of oil is 8.0 cm . Stipulate the density of the oil.
5. What force acts on the area of 1.1 dm^2 at atmospheric pressure $1\,000 \text{ hPa}$?
6. A tourist measures atmospheric pressure $1\,025 \text{ hPa}$ at the foot of a hill and pressure 950 hPa at the hilltop. What difference in altitude did he overcome?
7. A glass stopper is weighed in air and afterwards it is immersed wholly in water and reweighed. The readings obtained are 2.4 N in the air and 2.0 N in the water. Given that the density of water is $1\,000 \text{ kg}\cdot\text{m}^{-3}$, calculate the density of the stopper.
8. What minimum force is needed to cover a hole from the inside on a ship that is immersed in water? The hole is at a depth of 4 m and has an area 5 cm^2 .
9. At what depth is the pressure in water 10 times greater than atmospheric pressure 10^5 Pa ?

3. Archimedes' principle – objects immersed in a liquid appear to “lose weight”

- forces F , F' have the same size (why?) and they cancel each other (why?)
- $F_1 = A\rho_{h1} = Ah_1\rho g$ force on the upper side
- $F_2 = A\rho_{h2} = Ah_2\rho g$ force on the bottom
- upthrust (force of buoyancy, Archimedian force) $F_U = F_2 - F_1$

$$F_U = Ah_2\rho g - Ah_1\rho g = A\rho g(h_2 - h_1) = A\rho gh = V_B\rho_L g$$

V_B ... volume of the body immersed ρ_L ... density of the liquid

upthrust = weight of fluid displaced

F_U depends only onand

F_U does NOT depend onand

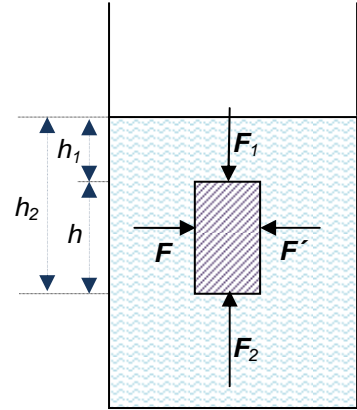

4. Behaviour of bodies immersed

depends on the resultant force (components = force of gravity and upthrust)

label in the figures :
 upthrust (F_U)
 force of gravity (F_g)
 volume of the body (V_B)
 density of the liquid (ρ_L)

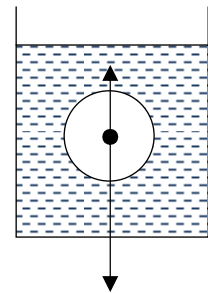

a)

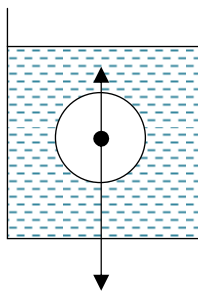

$F_U < F_g$
 $V_B\rho_L g < V_B\rho_B g$
 $\rho_L < \rho_B$
 the body sinks

b)

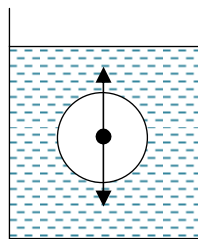

$F_U = F_g$
 $V_B\rho_L g = V_B\rho_B g$
 $\rho_L = \rho_B$
 the body floats
 at ANY depth

c)

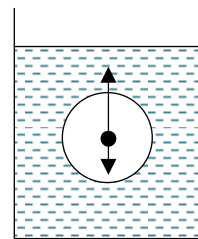

$F_U > F_g$
 $V_B\rho_L g > V_B\rho_B g$
 $\rho_L > \rho_B$
 the body rises until
 partly immersed

5. Partly immersed bodies

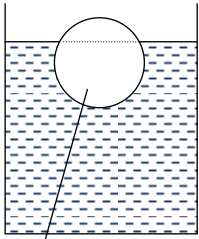

V'

volume immersed
(not the whole one)

Use - hydrometer

rise until partly immersed – until the force of gravity balances the upthrust
zero resultant = no motion

$$F'_U = F_g$$

$$V'_B \rho_L g = mg$$

$$V'_B \rho_L = m \quad \dots \text{ valid for PARTLY immersed bodies only}$$

(mass of the liquid displaced = mass of the whole object)

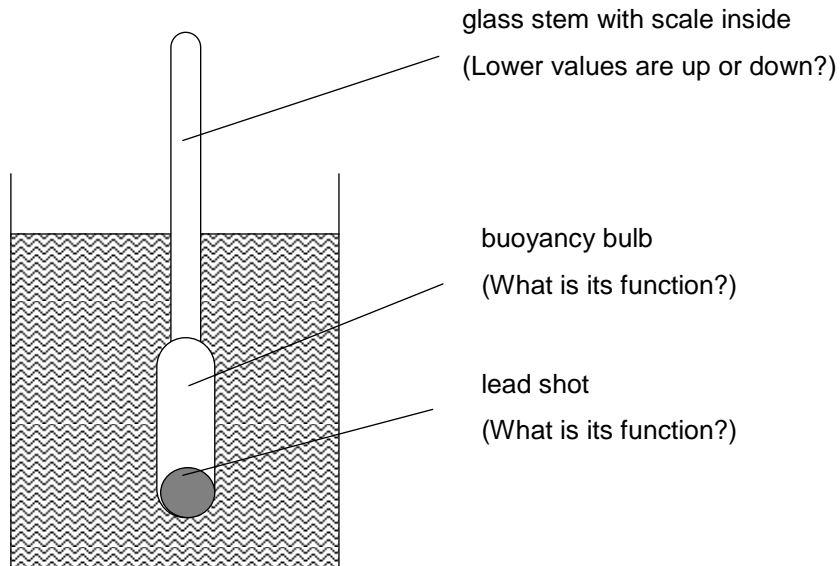

6. Hydrostatic paradox

The liquid in the vessels is the same and so is the height. The pressure on the bottom is the same though there is a different mass of the liquid in the vessels.

$$p_{h1} = p_{h2} = p_{h3} = h\rho g$$

$$F_1 = F_2 = F_3 \dots \text{ force on the base}$$

$$F_{g1} \neq F_{g2} \neq F_{g3} \dots \text{ force of gravity}$$

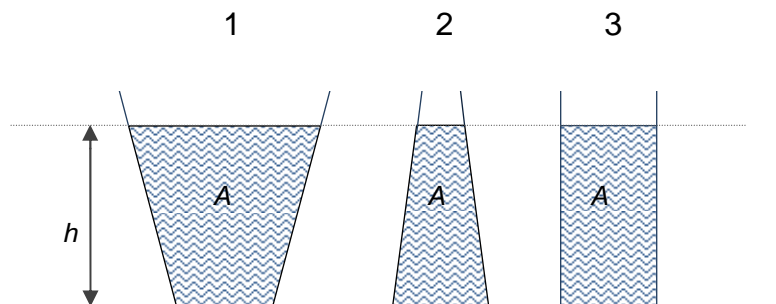

Where is the force of gravity equal to the force on the base? Why is it in other examples bigger/smaller?

Questions:

10. An ice floe has a shape of a square board of an area 1 m^2 and width 35 cm. What is minimum mass of a weight which has to be put on the middle of the floe so that the floe is fully immersed in water?
11. 1000 g weight of a) copper b) aluminium is immersed in water. Which upthrust is greater, on a) or on b)?
12. An iceberg floats in water. What part is immersed? (express as a percentage)
13. A paper ship of mass 3 g floats on the surface of water. On the bottom of the ship is put a weight of mass 16 g.
 - a) State the volume of the part immersed in water.
 - b) State the change of volume when we take the weight out.

L2/ 308-349

Discuss the motion of balloons:

B: FLUIDS IN MOTION

Ideal fluid

The following two equations will be valid for an ideal LIQUID only, because we assume constant density (incompressibility). We will assume a steady flow – streamlines do not cross each other or turn back.

1. Equation of continuity

= the law of conservation of MASS for a moving liquid – mass of the liquid passing any cross-section must be the same

Sketch streamlines and vectors of velocity \mathbf{v}_1 and \mathbf{v}_2 into the tube:

$$m_1 = m_2$$

$$\rho V_1 = \rho V_2$$

$$A_1 v_1 = A_2 v_2$$

$$Av = \text{const}$$



2. Bernoulli's equation

= the law of conservation of ENERGY for a moving liquid

$$E = E_K + E_p = \text{const}$$

$$E_K = \frac{1}{2} mv^2 = \frac{1}{2} \rho \Delta V v^2$$

$$E_p = W = Fs = pAs = \rho \Delta V$$

$$\frac{1}{2} \rho \Delta V v^2 + p \Delta V = \text{const} \quad / \Delta V$$

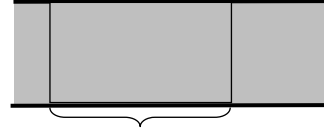

$$\frac{1}{2} \rho v^2 + p = \text{const}$$

$$\frac{1}{2} \rho v_1^2 + p_1 = \frac{1}{2} \rho v_2^2 + p_2$$

problem – how to state p ?

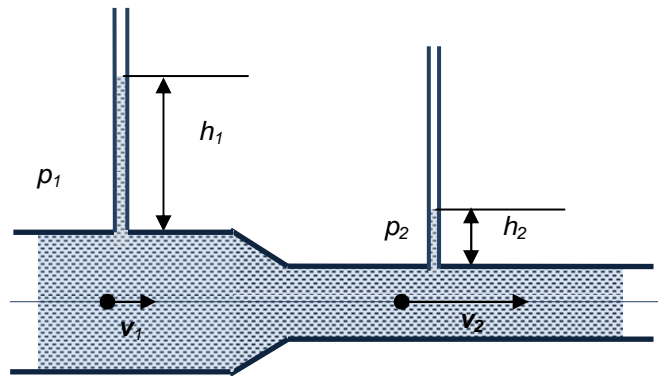

Hydrodynamic paradox
narrower part – LOWER p !!!

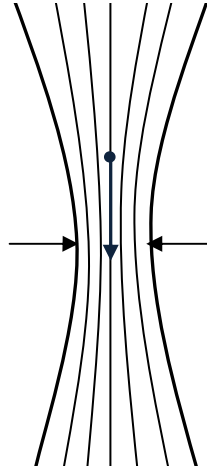

3. Applications

- jets and nozzles

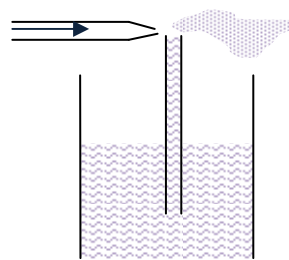

paint spraying

Find in additional materials or other sources examples of use this effect and sketch pictures:

- Bunsen burner
- filter pump
- motion of a spinning ball
- aerofoil – is the shape of a wing (seen in a cross-section area) producing a force perpendicular to the motion called LIFT (similar to hydrofoil).

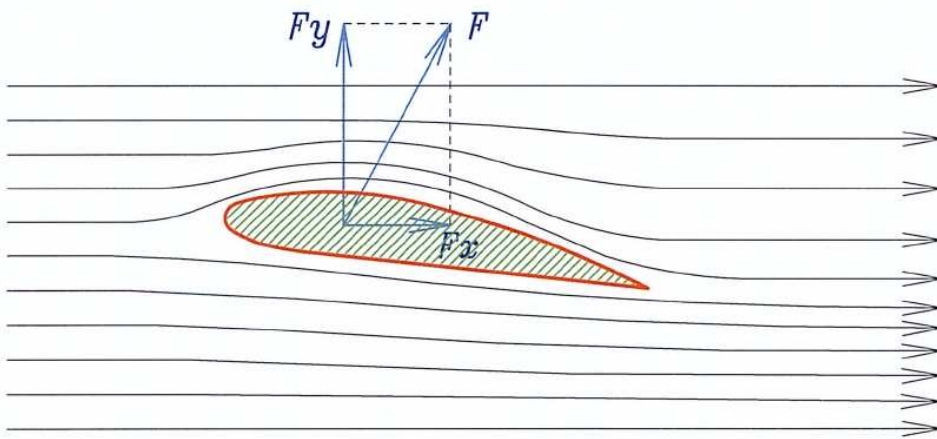

4. Speed of a liquid leaving the container

$$E_P \rightarrow E_K$$

$$mgh = \frac{1}{2}mv^2 \quad / : m$$

$$2hg = v^2$$

$$v = \sqrt{2hg}$$

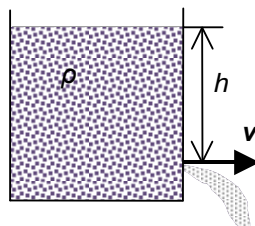

Questions:

14. 30 000 l of water flow through a pipeline of $A = 400 \text{ cm}^2$ in 20 min. Stipulate the speed of water.
15. Water flows at speed $1 \text{ m}\cdot\text{s}^{-1}$ through a hose of cross-section area 15 cm^2 . Stipulate the speed of water flowing through a constricted place of cross-section area 0.6 cm^2 ?
16. A garden hose has a cross-section area 5 cm^2 and at a constriction it has an area 1 cm^2 . Water spouts horizontally from a nozzle at height 90 cm above the earth. The stream of water falls down at the distance 2 m. What is the speed of water in the hose?
17. Find the speed of water flowing through a horizontal tube of a cross-section area 15 cm^2 if in a constricted place of area 5 cm^2 the pressure is lowered by 400 Pa? Neglect viscosity of water.
18. A measuring cylinder contains $1\,000 \text{ cm}^3$ of water which fills it to a height 20 cm. The cylinder has a small hole near its base through which water leaks out. The diameter of the hole is 0.6 mm.
 - a) What is the initial velocity of the escaping water?
 - b) What is the initial rate of loss of water?

L2/350-363

Real fluids

ideal fluid – zero viscosity

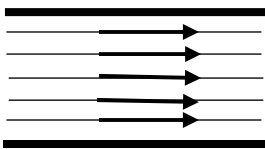

speeds inside

real fluid – viscous
(η - coefficient of viscosity)

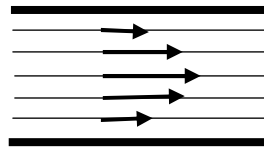

British system - motion of a SPHERE in any real fluid (η)

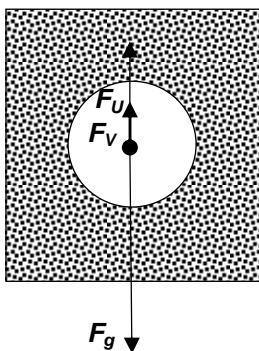

Which forces act on a sphere moving vertically in a real liquid?

- F_g -, $\downarrow (mg)$
- F_U -, $\uparrow (= \rho_L V_B g)$
- F_V -, acts against the motion – like the friction force

$F_V = 6\pi R\eta v$ Stoke's eqn

radius and speed of the sphere

State the direction of motion of the sphere on the figure above and write the eqn for all the forces acting on the sphere.

The viscous drag depends on the speed. So if the force of gravity is bigger than the upthrust (as it is on the figure), their resultant is initially pointed down and the sphere speeds up in this direction. As its speed rises, the viscous drag rises too which lowers the resultant (and therefore acceleration) until the forces are balanced. When there is zero resultant the sphere moves with a constant speed – terminal velocity v_t .

when $v < v_t$ $\vec{F}_g + \vec{F}_V + \vec{F}_U = \vec{F}_R \neq 0$

when $v = v_t = \text{const.}$ $\vec{F}_g + \vec{F}_V + \vec{F}_U = \vec{F}_R = 0$

Czech system – motion of objects (having different shapes – C) in the air, the coefficient of viscosity is in the eqn unfortunately replaced by density of the air ☹️

$$F_V = \frac{1}{2} C \rho A v^2 \quad \text{Newton's eqn}$$

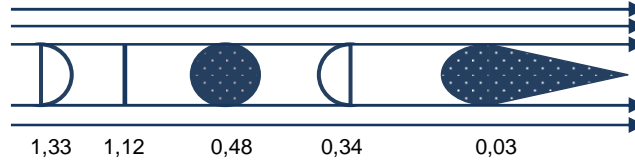

C ... coefficient of drag

Problem:

A parachutist reaches terminal velocity after the jump. Then he opens a parachute and his terminal velocity decreases. State forces acting in both situations and discuss which forces changed when the parachute had opened.

Questions: L2/364-366

Answers:

1. 200 kPa, 8 kN
2. 50 kPa, 2 500 kN
3. 210 000 kPa
4. $900 \text{ kg}\cdot\text{m}^{-3}$
5. 1 100 N
6. 580 m
7. $6\,000 \text{ kg}\cdot\text{m}^{-3}$
8. 20 N
9. 90 m
10. 35 kg
12. 90 %
13. 19 cm^3 , 16 cm^3
14. $0.625 \text{ m}\cdot\text{s}^{-1}$
15. $25 \text{ m}\cdot\text{s}^{-1}$
16. $0.94 \text{ m}\cdot\text{s}^{-1}$
17. $0.32 \text{ m}\cdot\text{s}^{-1}$
18. $2 \text{ m}\cdot\text{s}^{-1}$, $0.56 \text{ cm}^3\cdot\text{s}^{-1}$