

ALTERNATING CURRENT

1. Alternating current (a.c.) and root-mean-square (r.m.s.) values

direct current (d.c.) – current flows in one direction only

alternating current (a.c.) – not any changing current, but when it changes as a „sine function“ – as it was induced when a magnet rotates regularly inside a coil

$u = U_m \sin \omega t$ — time
 instantaneous value amplitude (max. value) angular velocity of the magnet rotating inside the coil
 $\omega = 2\pi f$

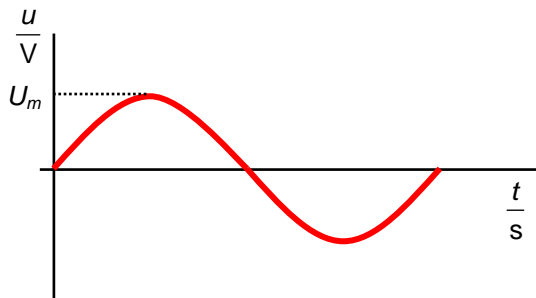

$$u = U_i = -\frac{d}{dt} N\Phi = -\frac{d}{dt} NBA \cos \omega t = NBA \omega \sin \omega t \Rightarrow U_m = NBA \omega$$

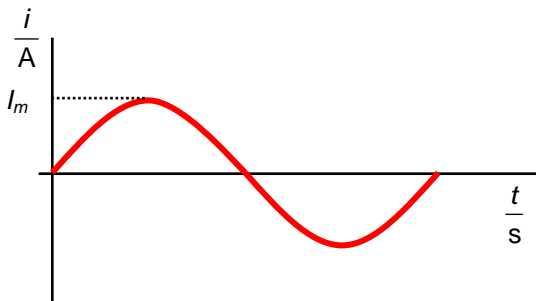

- problem: which value of the changing voltage/current can be used to describe the effects?

average – not (= 0)

maximum (or peak value or amplitude) – not, just once/twice during the period

root-mean-square = effective, r.m.s. value of alternating current or voltage

r.m.s. values

The same lamp is placed in a.c. and in d.c. circuit. If the brightness is the same, so the current has the same effect – the rate of energy conversion is the same, we can say that the value of the direct current in d.c. circuit represents the r.m.s. value of a.c. in the a.c. circuit and we call this value the effective or root-mean-square value of a.c.

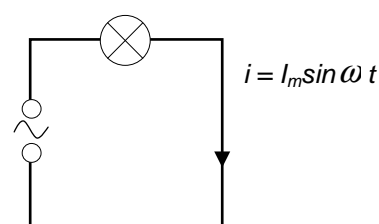
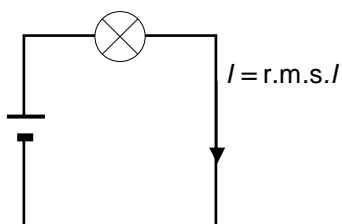

energy converted = power x time

energy converted = power x time

the same

$$P = UI = RI^2 = \bar{P}$$

$$P = RI_m^2 \sin^2 \omega t$$

area under P-t graph = energy

$$\bar{P} = \frac{1}{2} P_m$$

$$RI^2 = \frac{1}{2} RI_m^2$$

$$I^2 = \frac{I_m^2}{2}$$

$$I = \frac{\sqrt{2}}{2} I_m = I_{ef} \quad \dots \text{r.m.s. value of } i$$

$$U = \frac{\sqrt{2}}{2} U_m = U_{ef} \quad \dots \text{r.m.s. value of } u$$

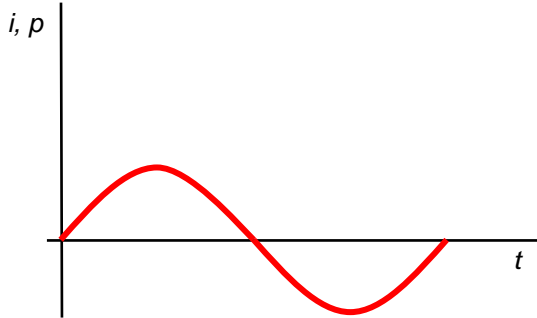

Questions:

1. Is the value of 230 V in the socket the peak one or the r.m.s. one? Calculate the second value.

2. A.c. circuits

a) resistor in a.c. circuit

$$i = \frac{u}{R} = \frac{U_m}{R} \sin \omega t = I_m \sin \omega t$$

$$I_m = \frac{U_m}{R}$$

amplitude of voltage
resistance
amplitude of a.c.

- u and i are IN PHASE (max and min simultaneously)

<http://www.walter-fendt.de/ph14e/accircuit.htm>

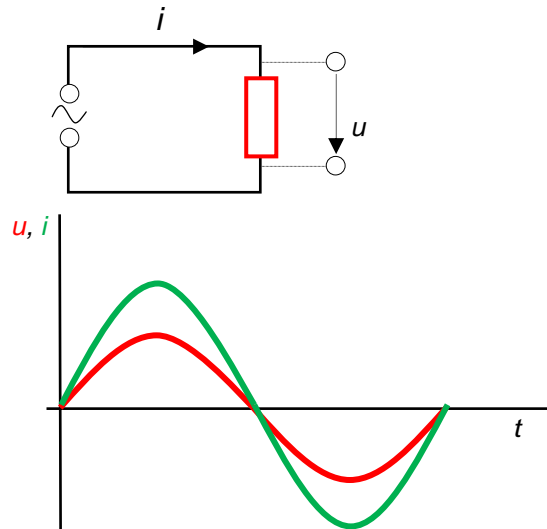

b) capacitor in a.c. circuit

a capacitor must be charged before we can measure the voltage across it

the phase difference between the voltage and current is $\frac{\pi}{2}$

$$u = U_m \sin \omega t$$

$$i = I_m \sin(\omega t + \frac{\pi}{2}) = I_m \cos \omega t$$

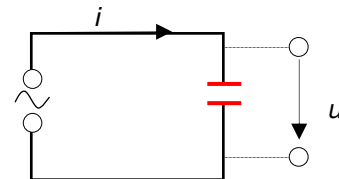

- resistance of a capacitor in a.c.c = **capacitive reactance X_C**

$$X_C = \frac{U_m}{I_m}$$

$$[X_C] = \Omega$$

$$X_C = \frac{1}{\omega C}$$

the capacitor is a bigger „obstacle“ to current when capacitance is small = it is charged quickly or when the frequency is small ($\omega = 2\pi f$)

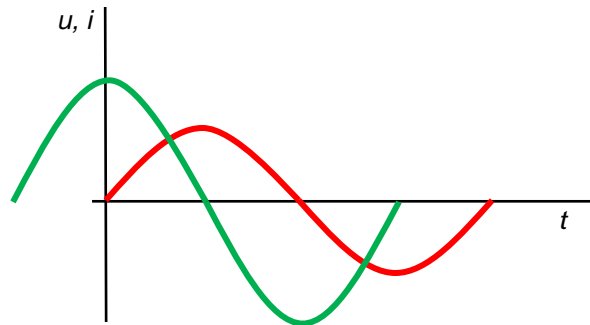

c) inductor (coil) in a.c. circuit

an inductor forms a voltage against the changing current so the current is delayed

the delay is $\frac{\pi}{2}$

$$u = U_m \sin \omega t$$

$$i = I_m \sin(\omega t - \frac{\pi}{2}) = -I_m \cos \omega t$$

- resistance of an inductor in a.c.c. = **inductive reactance X_L**

$$X_L = \frac{U_m}{I_m}$$

$$[X_L] = \Omega$$

$$X_L = \omega L$$

inductor is a bigger „obstacle“ to current when the coil has a big inductance and when the current changes quickly

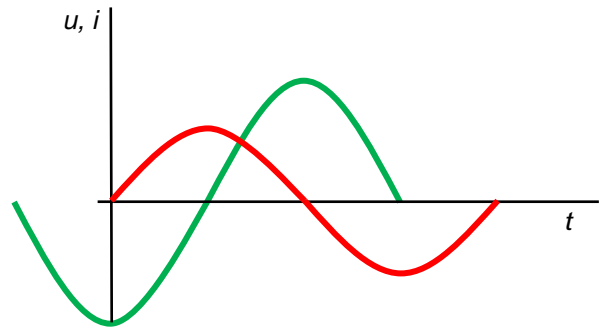
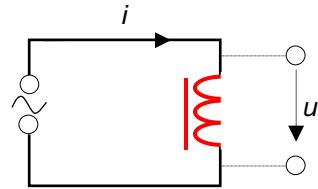

phasor diagrams

phasor = a vector having the size of U_m or I_m which rotates with angular velocity $\omega = 2\pi f$ and its projection represents the instantaneous value of voltage or current

resistor

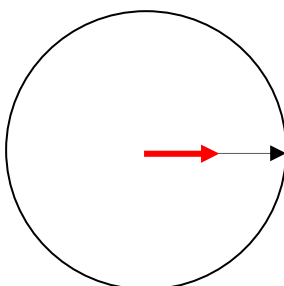

capacitor

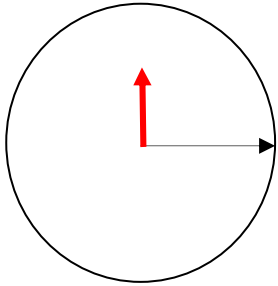

inductor

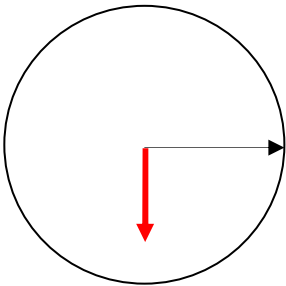

d) RLC in series

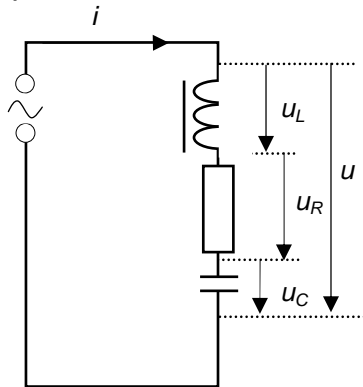

the current is the same – in phase

voltage differs (amplitudes, phase)

task – find the relation between them

• phasor diagram

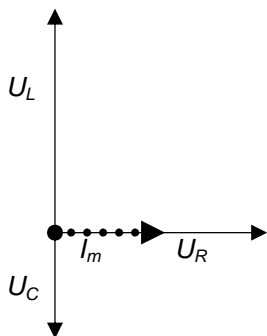

$$U_m^2 = U_R^2 + (U_L - U_C)^2$$

$$Z^2 I_m^2 = R^2 I_m^2 + (X_L - X_C)^2 I_m^2$$

$$Z = \sqrt{R^2 + (X_L - X_C)^2} \dots$$

impedance = resistance of R,L and C in a series a.c. circuit

$$[Z] = \Omega$$

$$\tan \varphi = \frac{U_L - U_C}{U_R} = \frac{X_L - X_C}{R}$$

- series resonance**

When $X_L = X_C$ the voltages across the capacitor and inductor balance each other and it behaves as if there is only the resistor – maximum current passes.

$$X_L = X_C$$

$$\omega L = \frac{1}{\omega C}$$

$$2\pi f_0 L = \frac{1}{2\pi f_0 C}$$

$$f_0 = \frac{1}{2\pi\sqrt{LC}} \quad \dots \quad \text{resonance frequency}$$

Questions:

2. A 1 mF capacitor is joined in series with a 2.5 V, 0.3 A bulb and a 50 Hz supply. Calculate the r.m.s. value of p.d. of the supply to light the lamp to its normal brightness and the r.m.s. values of p.ds across the capacitor and the bulb.

3. A 2 H inductor of resistance 80Ω is connected in series with a 420Ω resistor and 240 V, 50 Hz supply. Find the current in the circuit and the phase angle between the voltage and current in the circuit.

4. A circuit consists of an inductor of 0.2 mH and resistance 10Ω in series with a variable capacitor and a 0.1 V (r.m.s.), 1 MHz supply. Calculate the capacitance to give resonance and the p.ds across the inductor and the capacitor at resonance.

5. Sketch a graph representing how resistance, inductive reactance, capacitive reactance and impedance change with frequency.

L5/319-321, 323-339, 341-355, 367-372

e) parallel (R)LC circuit

can be used in tuning circuits to choose a signal with a certain frequency (f_0)

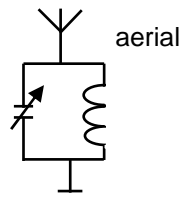
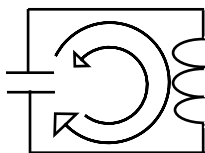

- function :**

The capacitor is charged („from outside“ – sketch!) and then disconnected. If there were no coil, it would only be discharged in a very short time by a huge current. But if there is a coil, the current cannot rise quickly because of self-induction and it rises until the capacitor is discharged. Then the capacitor does not supply the current but it cannot stop immediately because of the coil. The capacitor is charged in the opposite direction and then discharged again – electrical oscillations are formed. Their period (time to get the capacitor charged again in the same polarity) depends on the inductance and capacitance.

$$X_L = X_C$$

$$\omega L = \frac{1}{\omega C}$$

$$2\pi f_0 L = \frac{1}{2\pi f_0 C}$$

$$f_0 = \frac{1}{2\pi\sqrt{LC}} \dots \text{natural frequency}$$

<http://www.walter-fendt.de/ph14e/osccirc.htm>

- resonance:
These electrical oscillations are damped a lot (voltage and current gradually fall, frequency stays the same). To keep the oscillations energy must be supplied from outside. The most efficient way is when the frequency of the outer signal is the same as the natural one = resonance. This can be used in tuning circuits. We can change f_0 changing the capacitance, inductance or in parallel RLC circuit the resistance.

L5/ 398-400,402-403, x404, 405

3. Power in a.c. circuits

- a.c. circuit without inductor or capacitor

See previous part **r.m.s. values**. When voltage is in phase with current

$$p = Ri^2 = R I_m^2 \sin^2 \omega t = P_m^2 \sin^2 \omega t$$

$$P = \frac{1}{2} P_m$$

power in a.c.c
with resistors only

$$P = UI$$

r.m.s. voltage r.m.s. current

- a.c. circuit with inductor and/or capacitor

Useful energy conversion (into heat, light...) takes place only on resistors. On capacitors and inductors the electrical energy supplied is converted only into an electric (on C) or magnetic (on L) field. This means that maximum efficiency is when there is zero phase angle. The bigger the phase angle, the lower the **active power**.

$$P = UI \cos \varphi = P_S \cos \varphi$$

active power power factor apparent power (can be measured in unit VA)

$$[P] = W$$

L5/374-379

Answers:

1. 325 V
2. 2.7 V; 0.96 V; 2.5 V
3. 0.3 A; 52°
4. 0.13 nF; 13 V