

CRUDE OIL AND ITS COMPOSITION

1. Use a textbook to answer the following questions:

- a. How was crude oil formed?
- b. What is crude oil chemically?
- c. How can the components of crude oil be separated?
- d. Add labels to the diagram.

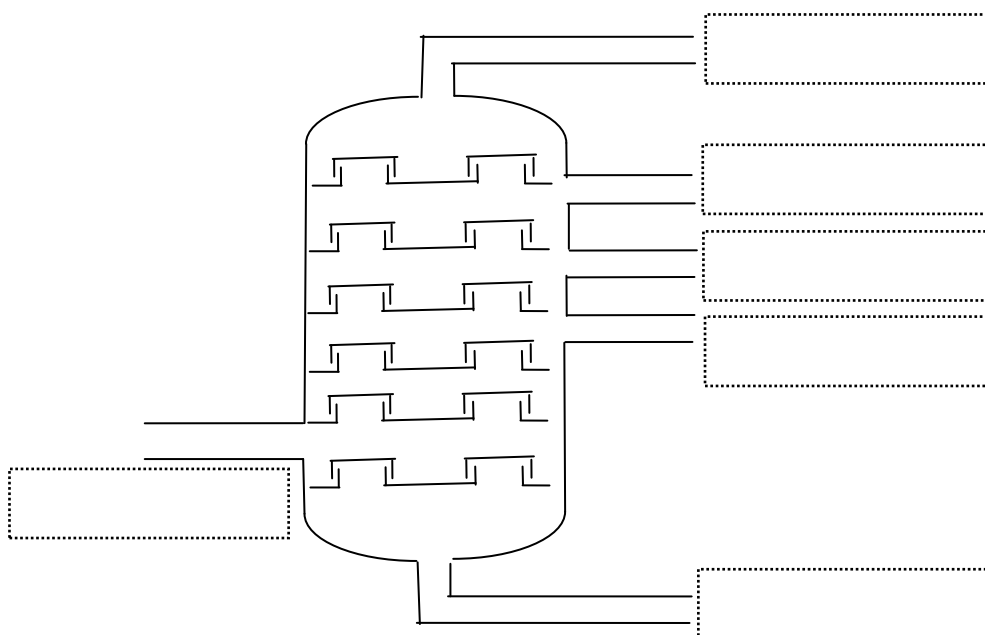

- e. What are the compositions and uses of fractions of crude oil?
- f. How are further fractions –lubricating oils and waxes obtained?
- g. Why must they be obtained this way?
- h. What is the name and the use of the material left from the residue after removing lubricating oils and waxes?
- i. Compare the properties of fractions of crude oil.

ALKANES

= saturated hydrocarbons, i.e. hydrocarbons with bonds only.

General formula: $C_nH_{\dots\dots\dots}$

Naming alkanes:

Straight -chain alkanes:

1. *Fill the table*

CH ₄		C ₆ H ₁₄	
	ethane	C ₇ H _{.....}	
	propane		octane
	butane		nonane
C ₅ H ₁₂			decane

Branched-chain alkanes:

Name of the longest unbranched chain + names and positions of the alkyl groups

ALKYL GROUP = a group made from an alkane by removing one hydrogen atom,
 general formula: $C_nH_{\dots\dots\dots}$, name derived from the name of the alkane, suffix -.....

2. *Fill the table*

-C ₃ H ₇			butyl
	ethyl	-CH ₃	

The carbon atoms in the longest unbranched chain are numbered in such a way that the name includes the lowest numbers.

3. *Choose the correct names for the following alkanes and explain why the other formulae are incorrect.*

a.

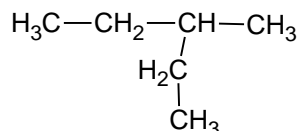

2-ethylbutane

3-ethylbutane

3-methylpentane

b.

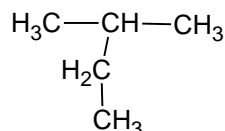

2-methylbutane

3-methylbutane

2-ethylpropane

More alkyl groups attached to main chain – in the name they are listed alphabetically, the prefixes (di, tri,...) do not affect the alphabetical order.

4. Name the following alkanes:

a.

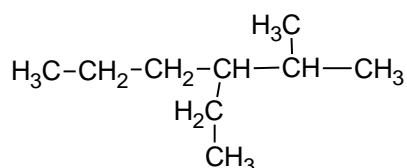

b.

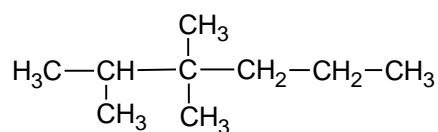

c.

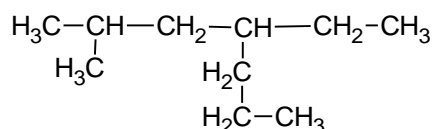

d.

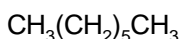

e.

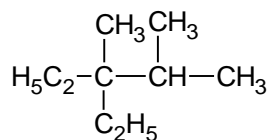

f.

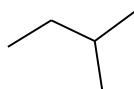

5. Write the formulae of the following alkanes

a. 2,3-dimethylbutane

d. 4-ethyl-2,2,3-trimethylheptane

b. 3-ethylpentane

e. 4-propyloctane

c. ethane

f. 3,4-diethyl-2,3,5-trimethylhexane

Physical properties

Boiling points, melting points, densities and viscosities of alkanes *increase/decrease* with the increasing number of carbon atoms. This is caused by *increasing/decreasing* forces between molecules.

$\text{CH}_4 - \text{C}_4\text{H}_{10}$ are....., $\text{C}_5\text{H}_{12} - \text{C}_{16}\text{H}_{34}$ are, $\text{C}_{17}\text{H}_{36}$ and higher are

Branched-chain alkanes have *higher/lower* boiling points than straight-chain alkanes with the same number of carbon atoms.

Alkanes *are/are not* soluble in water because they have *non-polar/polar* molecules.

6. Put the following alkanes in order with respect to increasing boiling point:

hexane

2,2-dimethylpropane

pentane

Chemical properties of alkanes

1. Burning alkanes

Complete combustion

1. *Finish and balance the equations:*

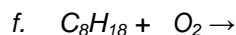
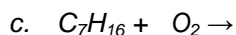
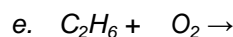
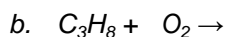
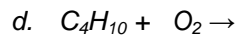
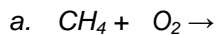

2. *Use the data in the table to plot a graph of ΔH_c against the number of carbon atoms for methane to hexane.*

Alkane	ΔH_c (kJ·mol ⁻¹)	Alkane	ΔH_c (kJ·mol ⁻¹)	Alkane	ΔH_c (kJ·mol ⁻¹)
methane	-890	propane	-2220	pentane	-3509
ethane	-1560	butane	-2877	hexane	-4195

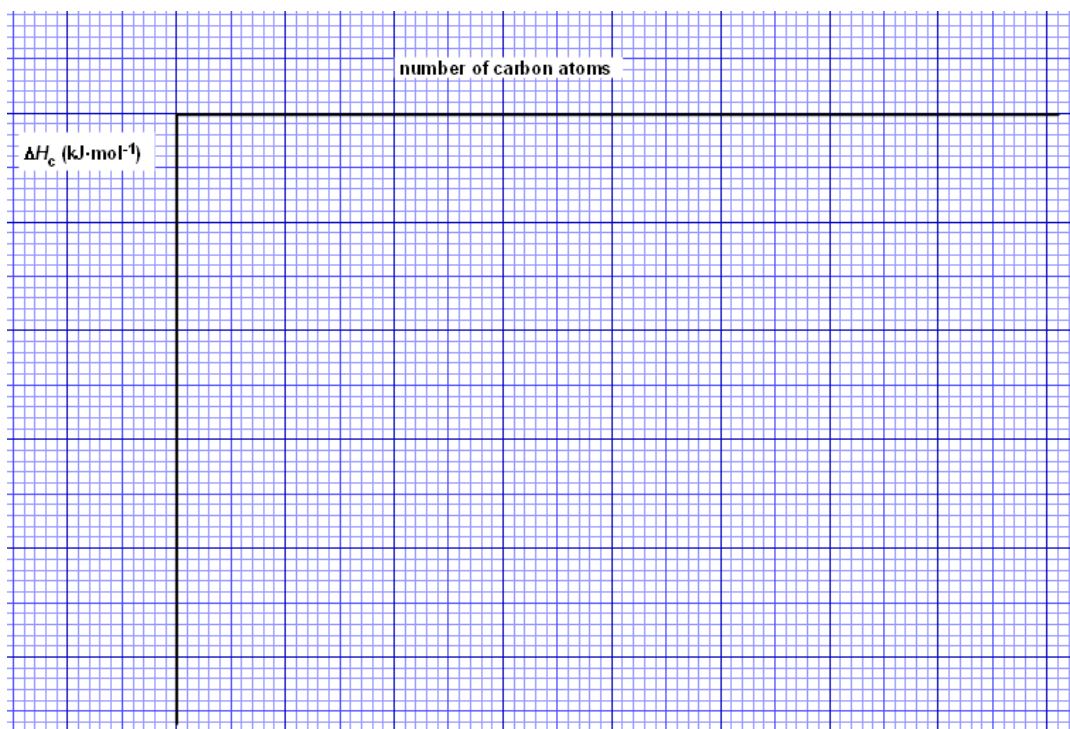

- What is the structural difference between two neighbouring alkanes?*
- What is the difference between their enthalpy changes of combustion?*
- Predict the enthalpy change of combustion of octane.*
- What heat is liberated by burning 1 dm³ of octane ($\rho = 0.692 \text{ g·cm}^{-3}$)?*

Burning gasoline in car engines

Revision of physics (4 stroke engine):

- Intake: The mixture of vapour and is forced into the
-
- Power: the mixture of fuel and air is by a The expansion caused by increased number of of the gases and by increased pushes the and its movement is transferred into the movement of
-

Efficiency = about 35%, i.e. 35% of the energy produced by the combustion is converted to energy and the rest (65%) is converted to

Octane rating:

If gasoline contains a lot of straight-chain alkanes it may ignite too quickly (before the spark occurs) and this causes so-called of the car engine. It decreases its efficiency. Branched-chain alkanes burn more smoothly.

Heptane – ignites prematurely → octane number

2,2,4-trimethylpentane – the best properties → octane number

Octane number 95: Petrol behaves as a mixture of 95 parts of and parts of

Incomplete combustion – in the limited supply of oxygen → CO, C (soot) is produced

2. Cracking alkanes

At a high or in the presence of a big molecules of alkanes break down to smaller molecules, e.g. $C_{12}H_{26} \rightarrow C_{10}H_{22} + \dots$

- Production of from
- Production of

3. Halogenation = reactions with

$CH_4(g) + Br_2(g) \rightarrow CH_3Br(g) + HBr(g)$ occurs in the presence of only

3. *What kind of reaction is this?*

4. *Is there more probable homolytic or heterolytic fission of the bonds?*

$$\Delta H_D(Br-Br) = 193 \text{ kJ}\cdot\text{mol}^{-1}$$

$$\Delta H_D(CH_3-H) = 435 \text{ kJ}\cdot\text{mol}^{-1}$$

5. *Which of these two bonds is more likely to be broken first?*

Reaction mechanism: *electrophilic/nucleophilic/free radical* substitution S....



MINISTRY OF EDUCATION,
YOUTH AND SPORTS

INVESTICE DO ROZVOJE VZDĚLÁVÁNÍ



- Initiation: $\text{Br}-\text{Br} \rightarrow \dots + \dots$ highly reactive \dots are formed. The bond is broken *homolytically/heterolytically*. The energy needed for breaking the bond is supplied by \dots
 - Propagation: Highly reactive \dots attacks a molecule of \dots
 - $\text{Br}\cdot + \text{CH}_4 \rightarrow \dots$
 - \dots
 - Termination: Two radicals meet and combine together:
4. Reforming: straight-chain alkanes are converted in the presence of a catalyst (Al_2O_3) into:
- a. \dots -chain alkanes \rightarrow increasing of \dots number
 - b. cycloalkanes
5. Elimination: $\text{CH}_3-\text{CH}_3 \xrightarrow{\text{Pt}} \text{H}_2 + \dots$

Important alkanes:

Methane

colourless, *toxic/non-toxic* \dots , causes \dots effect, major component of \dots gas, used as a \dots and for the production of \dots : $\text{CH}_4 + \text{H}_2\text{O} \rightarrow \text{CO} + \dots$

It forms an \dots mixture with the air.

6. Draw the box diagram for a methane molecule. What orbitals take part in bonding?

7. What is the shape of a methane molecule?

Ethane

8. What are the physical properties of ethane?

Ethane is used for the production of \dots

9. What type of hybridisation is there in a molecule of ethane?

There are many possible shapes of an ethane molecule because of possible \dots around the single bond. Two of them are known as:

an eclipsed conformation a staggered conformation

Propane, butane

= together with methane and ethane components of \dots gas. Liquefied propane and butane (known as \dots) are stored in portable metal cylinders and used as \dots

Cycloalkanes

= saturated hydrocarbons with a cyclic chain, general formula C_nH_{2n}

10. Use the models of molecules to predict the most stable carbon rings.

Cyclohexane C_6H_{12} is a *gas/liquid/solid* used as a *polar/non-polar* solvent. Its molecules occur in two conformations:

chair

boat

11. Work out the names or formulae for:

a. methylcyclopentane

b. 1-ethyl-2-methylcycloheptane

c. cyclooctane

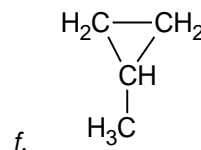
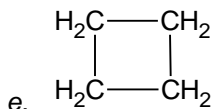
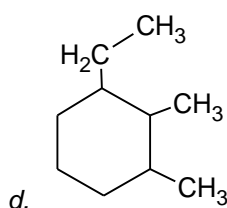

More complicated side chain or more cycloalkyls attached to a carbon chain → the substance is considered to be an alkane substituted by cycloalkyls:

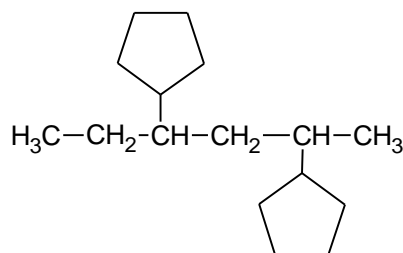
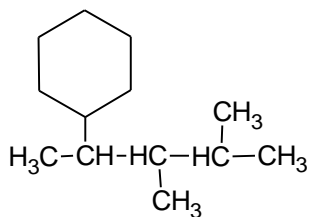



MINISTRY OF EDUCATION,
YOUTH AND SPORTS



INVESTICE DO ROZVOJE VZDĚLÁVÁNÍ

UNSATURATED HYDROCARBONS

= hydrocarbons with less than the maximum number of hydrogen atoms, i.e. hydrocarbons with or bonds

ALKENES

= hydrocarbons with one bond in an open carbon chain. General formula: C_nH_{\dots}

The nature of the double bond

Alkenes are *more/less* reactive than alkanes.

$E(C-C) = 346 \text{ kJ}\cdot\text{mol}^{-1}$, $E(C=C) = 598 \text{ kJ}\cdot\text{mol}^{-1}$, double bond *is/is not* twice as strong as a single bond, i.e. the two bonds in the double bond *are/are not* identical.

1. Compare C–C and C=C bond lengths.

The double bond consists of:

σ -bond: highest electron density the nuclei.

π -bond: highest electron density and the plane connecting the nuclei

Orbitals participating in π -bond do not hybridise.

2. What type of hybridisation is there in the molecule of ethene and what is its shape?

Consequencies:

- π -bond is weaker \rightarrow may be easily broken \rightarrow higher reactivity of alkenes
- no possible rotation around the double bond \rightarrow geometric (cis, trans) isomerism

Naming:

Straight-chain alkenes: suffix **-ene** with the number of carbon from which the double bond comes out.

3. Write the structures of all the straight-chain alkenes with the following molecular formulae and name them:



4. Write the formulae for:

- a. hept-1-ene
b. *cis* hex-2-ene
c. *trans* hex-3-ene
d. *trans* oct-2-ene

Branched alkenes: the main chain is not the longest one but the one with the highest number of double bonds, carbon atoms are numbered from the end nearest the double bond.

http://www-personal.une.edu.au/~sglover/Alkenes_tutorial/sld001.htm

5. Name the following alkenes:

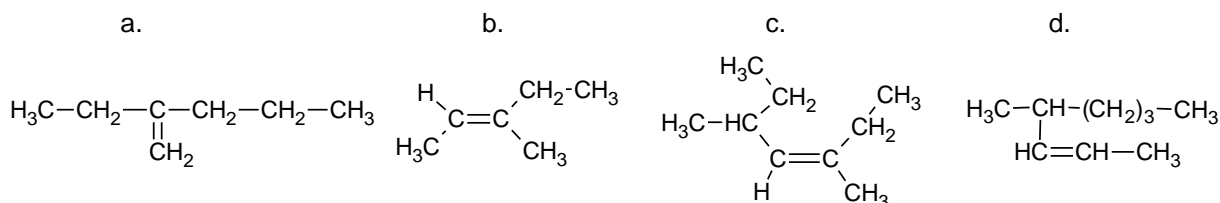

6. Make the formulae for:

- a. 4-methylpent-2-ene
b. 3-ethyl-2-methylpent-2-ene
c. *trans* 2,2,4-trimethylhex-3-ene

Chemical properties of alkenes

1. Addition reactions

- a. Reactions with halogens (halogenation)

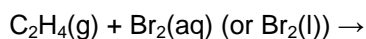

mechanism:

The reaction with bromine water ($\text{Br}_2(\text{aq})$) is used for testing of the presence of a

- b. Reactions with hydrogen halides (.....)

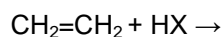

mechanism:

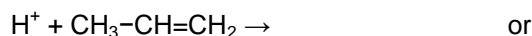
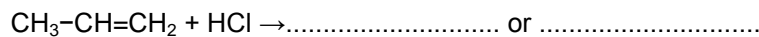



MINISTRY OF EDUCATION,
YOUTH AND SPORTS



INVESTICE DO ROZVOJE VZDĚLÁVÁNÍ

4. Debromination of bromoalkanes

Alkadienes (dienes)

= hydrocarbons with two double bonds in an open chain.

$C=C=C$ double bonds

$C=C-C=C$ double bonds

$C=C-C_n-C=C$ ($n \geq 1$) double bonds

The most important: buta-1,3-diene used for the production of synthetic

9. Write the formula or names for the following dienes and classify them as cumulated, conjugated and insulated.

a. 2-methylbuta-1,3-diene

c. $CH=CH-C(CH_3)_2-CH=CH_2$

b. penta-1,2-diene

d. $CH_3-(CH_2)_4-CH=C=CH_2$

10. Find in this text about alkenes the uses of some important alkenes.

ALKYNES

= hydrocarbons with one bond in an open chain, general formula: C_nH_{\dots}

Triple bond consists of: one and two bonds.

1. Draw the box diagram for the molecule of ethyne. What type of hybridisation is there and what is its shape?



MINISTRY OF EDUCATION,
YOUTH AND SPORTS

INVESTICE DO ROZVOJE VZDĚLÁVÁNÍ



Naming: suffix **-yne**, the same rules as alkenes.

2. Draw the structures of all alkynes with the molecular formula C_6H_{10} and name them. (7)

3. Make the name or formulae for:

a. oct-2-yne

b. 3-ethyl-4-methylpent-1-yne

c. cyclohexyne

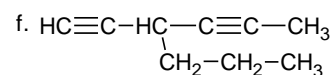
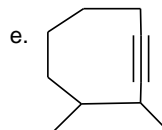
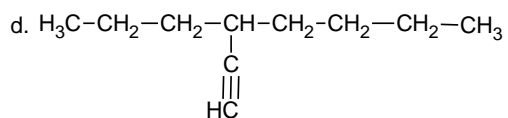

Preparation of ethyne

- Hydrolysis of CaC_2 : $CaC_2 + H_2O \rightarrow$
- From petroleum (crude oil) by cracking

expensive

Chemical properties of ethyne:

1. Addition reactions

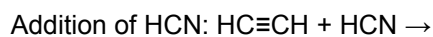
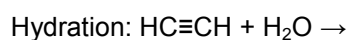
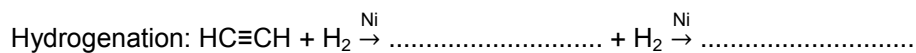



MINISTRY OF EDUCATION,
YOUTH AND SPORTS



INVESTICE DO ROZVOJE VZDĚLÁVÁNÍ

4. *Finish equations:*

- $\text{CH}_3\text{CH}_2\text{C}\equiv\text{CCH}_3 + \text{Cl}_2$ (excess) \rightarrow
- $(\text{CH}_3)_2\text{CHC}\equiv\text{CH} + \text{HBr}$ (excess) \rightarrow
- $\text{HC}\equiv\text{CCH}_3 + \text{H}_2$ (excess) $\xrightarrow{\text{Ni}}$
- $\text{CH}_3\text{CH}_2\text{C}\equiv\text{CH} + \text{HCl}$ (ratio of numbers of moles 1:1) \rightarrow
- $\text{CH}_3\text{C}\equiv\text{CH} + \text{H}_2\text{O}$ \rightarrow
- $\text{HC}\equiv\text{CCH}_2\text{CH}_3 + \text{HCN}$ \rightarrow

5. *Write down the equations for the polymerization of :*

- chloroethene (vinylchloride)*
- acrylonitrile*

2. Oxidation

- Burning:
 - complete combustion – ethyne (acetylene) in the mixture with pure oxygen is used for and metals
(It is stored in metal cylinders labelled with a stripe)
 - incomplete combustion: ethyne in air burns with a flame.
Generally: the higher number of multiple bonds the sooty flame
- + KMnO_4/H^+ \rightarrow carboxylic acids; permanganate solution

3. Acidic properties:

$\text{C}\equiv\text{C}$ group has a high electronegativity. When H is bonded to it, it easily an electron forming ion.

Test for the presence of a terminal triple bond:



6. *Decide which of the following substances react with an ammoniacal solution of silver nitrate and write the formulae of the products:*

- $\text{CH}_3\text{CH}_2\text{C}\equiv\text{CCH}_3$
- $(\text{CH}_3)_2\text{CHC}\equiv\text{CH}$
- $\text{HC}\equiv\text{CCH}_3$
- $\text{CH}_3\text{CH}_2\text{CH}=\text{CH}_2$

4. Polymerization



ARENES

= aromatic hydrocarbons = hydrocarbons with at least one benzene ring.

The word „aromatic“ originally comes from the fact that some of such hydrocarbons have a pleasant smell but now it is connected with their structure.



The structure of benzene was first suggested by Kekulé (German chemist, 1829-1896). He supposed that six carbon atoms are arranged in a hexagon and there are single and double bonds alternating between them. Each carbon atom bonds one more hydrogen atom. This theory is also supported by the fact that benzene burns

with a smoky flame. However, there are some problems with the Kekulé structure. One problem is that benzene may be expected to undergo the same reactions as alkenes, i.e. addition reactions which lead to breaking of the π -bond. However, benzene doesn't react with bromine water. The second problem is with the shape of the benzene molecule. According to the Kekulé structure it should be a hexagon where shorter double bonds alternate with longer single bonds, but the real shape is a regular hexagon, i.e. all the carbon-carbon bonds are of the same length. The modern view of the structure of benzene is: six carbon atoms in the corners of a regular hexagon. Each carbon atom has its valence electrons in one $2s$ and three $2p$ orbitals. $2s$ orbital and two $2p$ orbitals are hybridised forming hybrid sp^2 orbitals. They make bonds with two neighbouring carbon atoms and one hydrogen atom. The third $2p$ orbital is not hybridised and it is orientated perpendicularly to the plane of the carbon atoms. Six p orbitals of six carbon atoms overlap broadside on one with the two neighbouring ones forming so called π -complex of delocalised electrons which are shared equally by all the carbon atoms. The highest electron density of such π -complex is in two rings, one above and the second below the plane of the carbon ring. Such a system is very stable. This is expressed by a circle inside the hexagon.

1. *Draw*

a. *the Kekulé structure of benzene*

b. *p-orbitals forming π -complex of delocalised electrons*

c. *the simplified model of the modern structure of benzene using the description in the above text*

2. *Give one simple test tube reaction which can distinguish between cyclohexene and benzene.*

3. *Suggest a reason why benzene burns with a smoky flame.*

Naming of arenes:

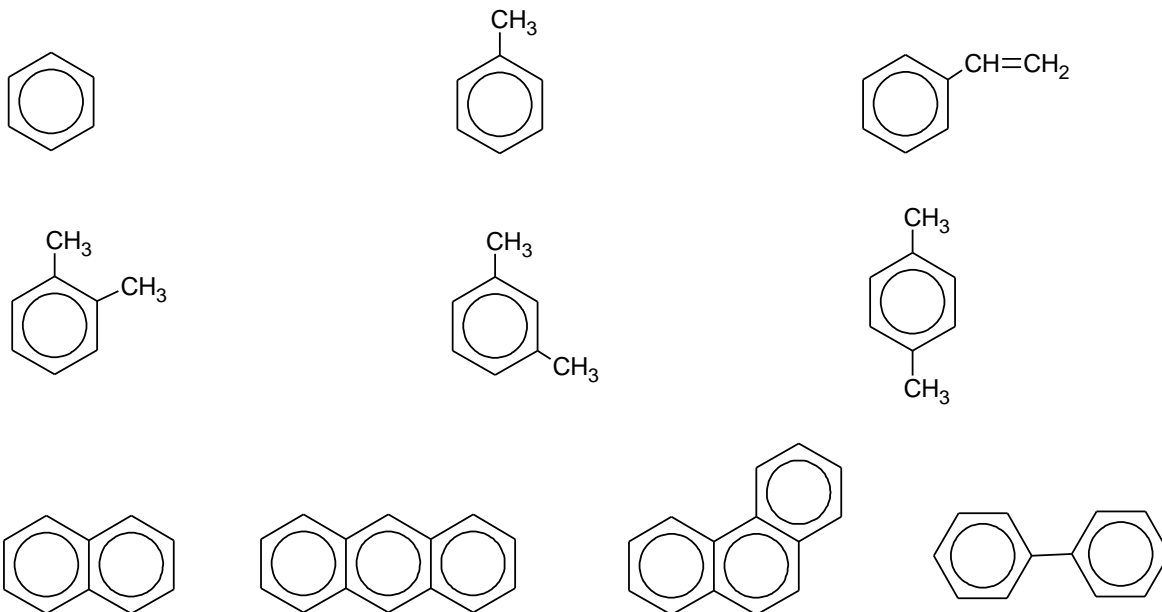

Aryl groups = groups derived from arenes by removing atom

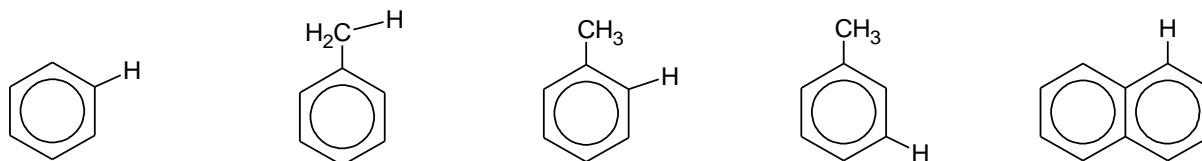

4. Write the structure for: a. *p*-tolyl

b. 2-naphthyl

5. Name the following compounds:

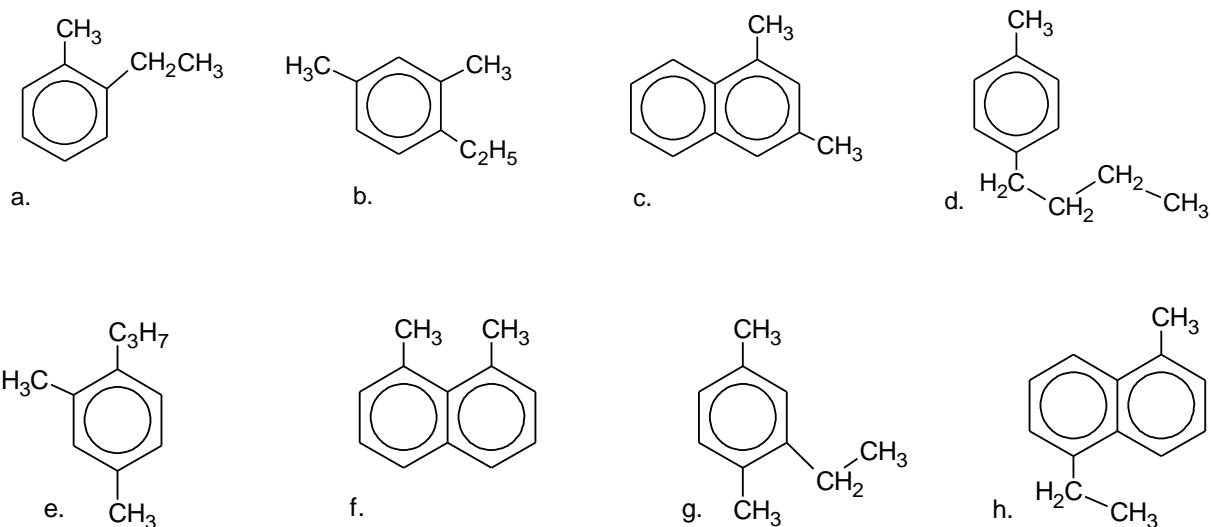

6. Write the structural formulae for:

a. 1,4-diethylbenzene

c. 1,7-dimethylnaphthalene

b. 1-ethyl-2-methylbenzene

d. 1-butyl-2-ethyl-3-vinylbenzene

Chemical properties of benzene

Benzene reacts neither with bromine water (or with bromine in the dark) nor with acidified permanganate solution. It means that benzene is unreactive towards addition and

1. substitution S.....

Mechanism:

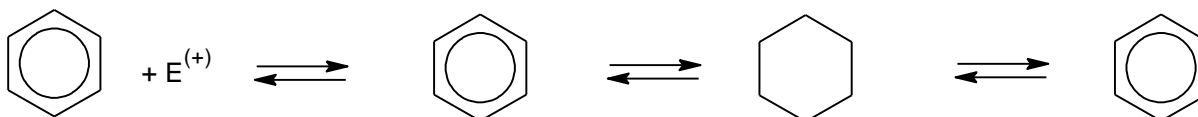

a. Nitration: nitrating mixture = conc. HNO_3 + conc. H_2SO_4

b. Halogenation

c. Sulphonation

d. Friedel-Crafts alkylation

2. addition A.....
- a. Hydrogenation, in the presence of

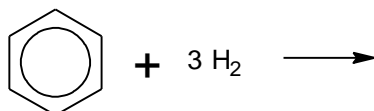

- b. Halogenation, in the presence of

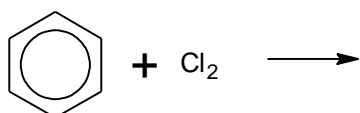

Position of substitution in benzene derivatives

Substituents already bonded to a benzene ring affect the rate and the position of further substitution.

- Ring activating substituents = *speed up/slow down* further substitution, *take/donate* electrons, direct the second substituents to the position and
alkyl groups, $-\text{NH}_2$, $-\text{OH}$, $-\text{OCH}_3$
- Ring deactivating substituents = *speed up/slow down* further substitution, *take/donate* electrons, direct the second substituents to the position
 $-\text{NO}_2$, $-\text{COOH}$, $-\text{SO}_3\text{H}$

Exception: **halogens** slow down further substitution but direct the second substituents to and position.

7. Write down the formulae of the major products of the following reactions:

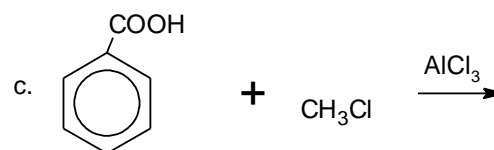
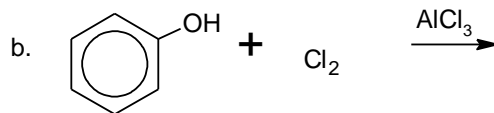
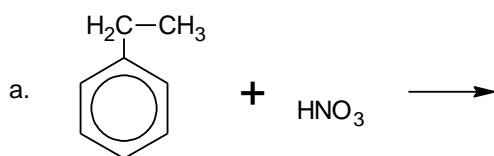

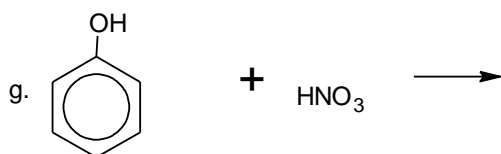
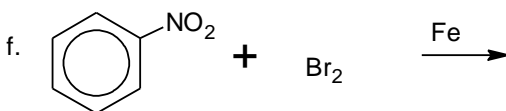
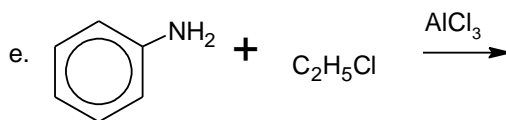
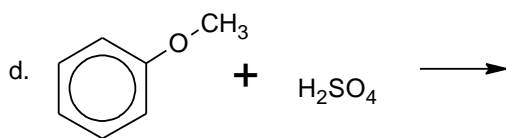

Chemical properties of methylbenzene (.....)

1. Reactions of the $-\text{CH}_3$ group:

a. halogenation, mechanism = substitution

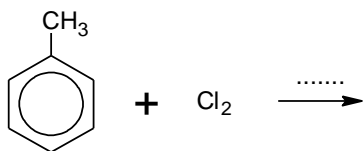

b. oxidation

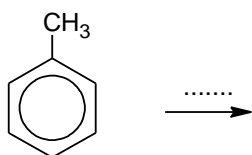

2. Reactions of the benzene ring:

= substitution

a. halogenation

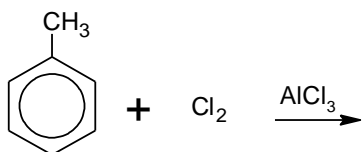

b. nitration

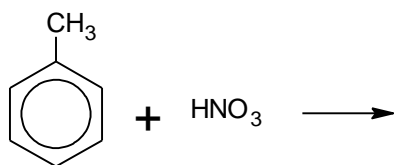

c. sulphonation

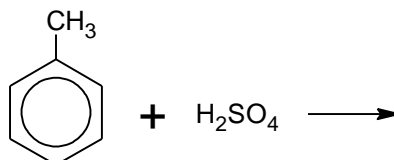

8. State the reactants and reaction conditions to convert:

- phenylamine to 2-methylphenylamine
- phenol to picric acid (2,4,6-trinitrophenol)
- nitrobenzene to 3-nitrobenzenesulphonic acid
- chlorobenzene to 1-chloro-4-ethylbenzene
- benzene to 2-nitrotoluene (2 steps)
- benzene to 3-nitrotoluene (2 steps)
- benzene to 3-chlorobenzoic acid (3 steps)
- benzene to 2-chlorobenzoic acid (3 steps)

Sources of aromatic hydrocarbons

9. Use the book *Chemistry in Context* to study two main methods of production of benzene.